

EFP Compack

All-in-one
Foam Solution



FM
Approved
components



The EFPCompack is the All-in-one Foam Solution for unmatched accuracy.

This system is ready to run. This plug and play system includes:

- Electronic Foam Proportioner (EFP®)
- Fire Lion Foam Pump
- Electric or diesel drive

The EFP® is an easy to maintain and easy to test fire safety system for the safe storage of combustible substances and flammable liquids. The foam pumps are specialized, rotary gear, positive displacement firefighting foam pumps. The drive is determined on the basis of the desired situation.

With this application you have the ideal all-in-one solution with which you are prepared for the future.

Main features:

- ✓ This system is ready to run; a plug and play system.
- ✓ This EFP Compack pursues the highest quality requirements based on the existing certifications.
- ✓ We can provide custom configurations.
- ✓ Proportioning accuracy is maintained regardless of temperature or viscosity of the foam concentrate.
- ✓ Mixing accuracy of 0,1%.
- ✓ Test provisions to test the system without actually mixing foam concentrate with water. So no loss of foam concentrate, no environmental damage and significant reduction in costs.
- ✓ A wide range of flow conditions while dosage accuracy is maintained.
- ✓ Self diagnostic.

Function

The EFP Compact is the all in one solution for unmatched accuracy.

This system is ready to run. This plug and play system includes:

- Electronic Foam Proportioner (EFP®)
- Fire Lion Foam Pump
- Electric or diesel drive

The EFP Compact is the easiest solution. You do not need to choose between options or modifications to get a complete set. The following options are included:

- real time waterflow and -pressure display
- real time concentrate flow and -pressure display
- real time display of actual and desired mixing rate

With this application you have the ideal All-in-one Foam Solution with which you are prepared for the future.

The EFP® is an incredibly accurate electronically controlled wide range foam proportioning system. The principle function of the EFP® is the accurate measurement of both the foam concentrates and the water supply with electromagnetic flow meters (EMF).

The EFP®'s heart, the central processing unit (CPU), measures out the correct amount of foam concentrate required for the proportioning and continually monitors the amount of foam mixed in. Two electronically operated valves control the flow at all times and maintain proper foam pressure.

The EFP® is equipped with a test mode which enables the operator to test the system without proportioning foam concentrate into the water flow. These types of tests can't be executed alongside the Firepacks trails on a weekly basis. The Fire Lion foam pump should be tested on a monthly basis. In test mode the foam concentrate measured and regulated by the EFP® is transferred back to the reservoir.

The Fire Lion foam pumps are specialized, rotary gear, positive displacement firefighting foam pumps. Drive options include electric motor or diesel engine. The foam pump will pump the foam concentrate to the EFP® during the test of fire mode. The EFP® injects the right amount of foam concentrate into the water discharge line.

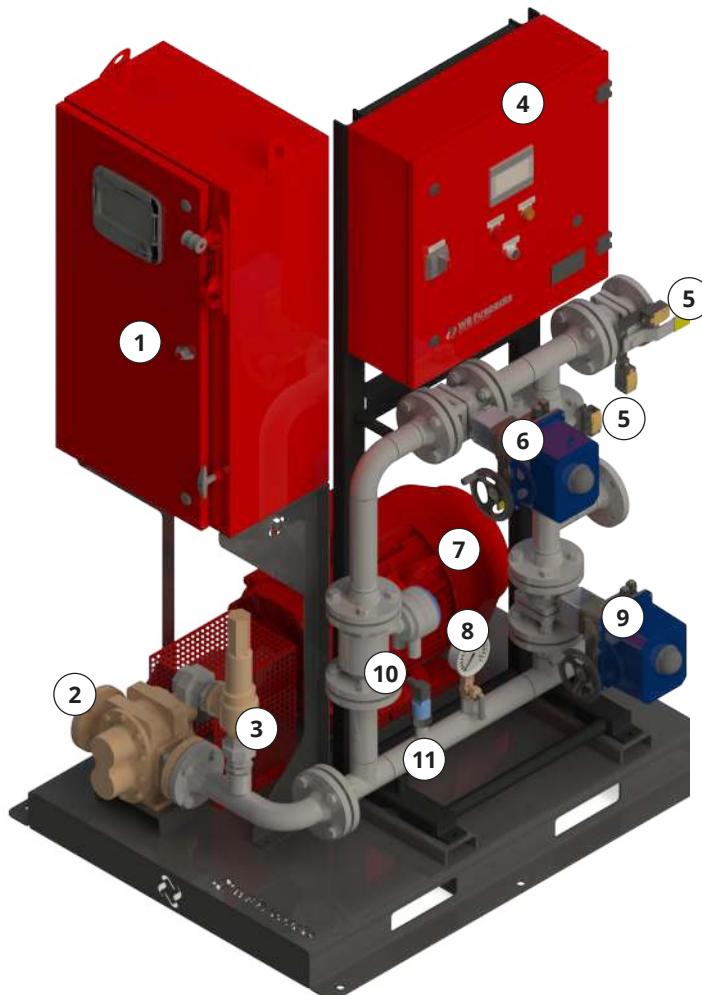

Construction

1. Controller electric motor
2. Foam pump
3. Pressure relief valve
4. Electric Foam Proportioner (EFP®)
5. Manual valves
6. Flow control valve
7. Electric motor
8. Pressure gauge
9. Pressure control valve
10. Electromagnetic flow meter
11. Pressure transducer

Function diagram

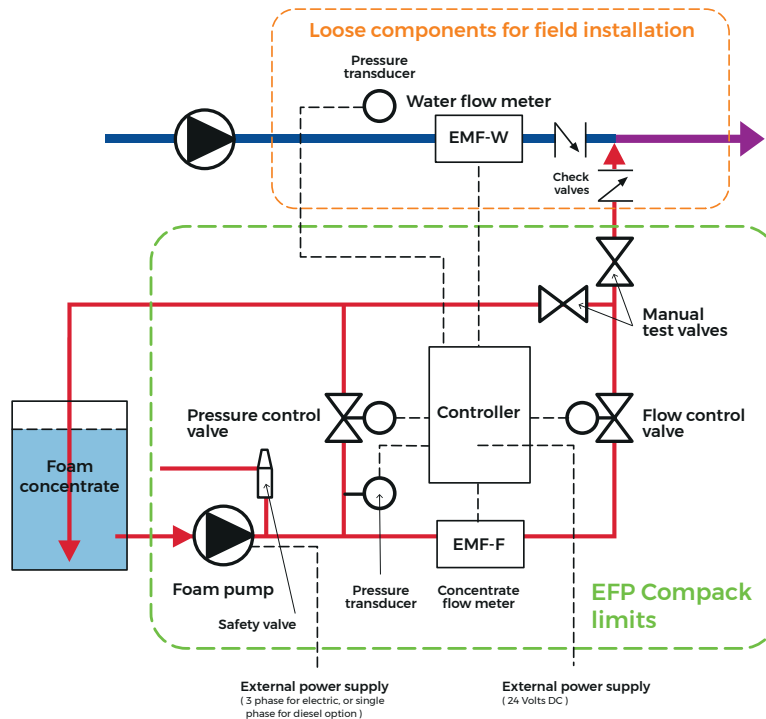

- ✓ EFP® units can be purchased separately or configured in systems with electric motors or diesel engines.
- ✓ The pressure transducer, water flow meter and check valve are delivered separately and other components can optionally be delivered separately for flexible field installation.
- ✓ A variety of configurations are available to provide solutions for your hazard.

Technical specifications

Working principle	: Closed loop based on EMF-flow meters
Controls	: Siemens PLC
Flow meter	: Krohne EMF (for foam and water circuits)
Pressure sensors	: Endress & Hauser, 0-25 bar, 4-20 mA
Regulation valves	: Electronically operated ball valves with V-port opening for accurate control
Start-up time	: 0 - 100% in 8 seconds
Construction	: DN 50, 316 stainless steel, flange connections
Monitor function	: - Continuous monitoring of the flowmeters - Continuous monitoring of the pressure transducers - Once per 24h valve-check (to monitor the valves and prevent sticking) - When in operation, continuous monitoring of the foam concentrate injection percentage
Alert	: Request by fire alarm or pump controller
Proportioning ratio	: 0,5 - 6%
Foam concentrate pressure	: - Non-listed max. 20,68 bar (300 psi) - FM Approved max. 18 bar (261 psi)
Proportioning accuracy	: Within 0,1% of the selected proportioning ratio
Operational temperature	: 4 ... 55 °C
Dynamic viscosity (<FM>)	: 1 ... 4000 cP (21 °C) (1 cP = 1 g / (cm · s))
Performance foam concentrate	: - Non-listed between 0,8 and 50 m ³ /h (4 and 220 USgpm) - FM Approved between 0,8 and 34 m ³ /h (4 and 150 USgpm)

Dimensions

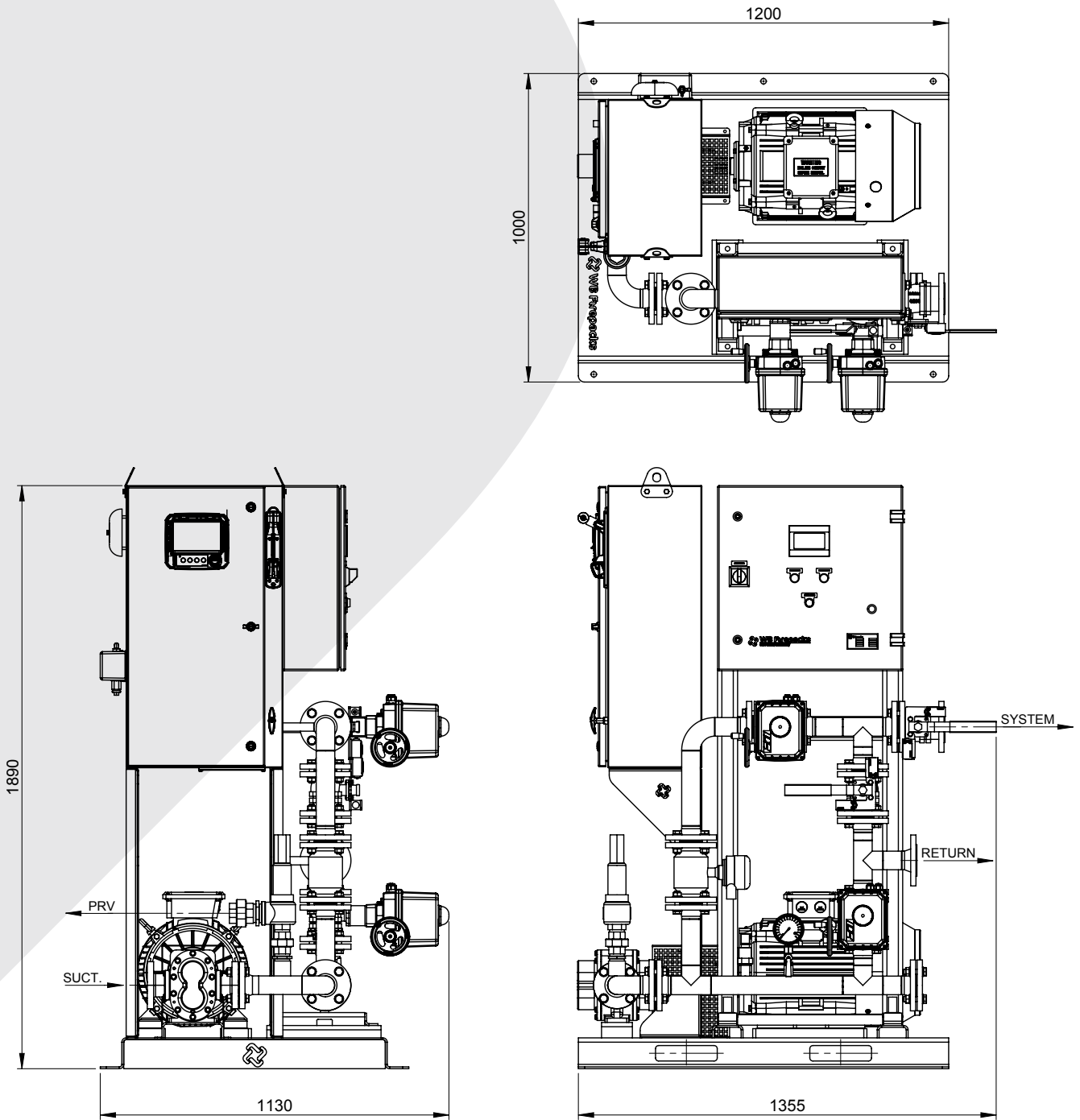

Dimensions may vary due to size of pump and engine.



Hoedemakersstraat 14 | Zwijndrecht | Netherlands
+31 (0)78 623 15 00 | firepacks@firepacks.com
www.firepacks.com